

# REMOVE DIESEL EXHAUST FROM YOUR FIRE STATION



**PLYMOVENT'S SOURCE CAPTURE AND REMOVAL SOLUTIONS WILL EFFECTIVELY EXTRACT DIESEL EXHAUST FROM FIRE STATIONS**

**PLYMOVENT**<sup>®</sup>  
clean air at work

Supported &  
Distributed by...



**FANTECH**  
Industrial Ventilation

# Protecting Our Firefighters Starts with Cleaner Air

At Fantech Industrial Ventilation, we are committed to delivering advanced ventilation and air quality solutions for industrial environments. As the exclusive Australian partner for Plymovent – a global leader in vehicle exhaust extraction – we are continuously supporting our emergency services with diesel exhaust source capture systems that remove toxic fumes from enclosed vehicle bays and response facilities.

Plymovent offers a comprehensive range of diesel exhaust extraction solutions, purpose-designed for the unique demands and specific requirement of emergency services, facilities and vehicles. From fully automatic rail systems and hose reels, to nozzles, fans, and smart monitoring. Every component works together as part of a complete system to ensure efficient and simple operation:



### Rail Systems:

Fully automatic rails for single or multiple bays, as well as options for undercarriage and overhead exhaust stacks. Simple connection and hands-free operation for maximum safety.



### Nozzles & Grabbers:

Quick-connect nozzles, including the Magnetic and Pneumatic Grabbers, ensure a secure seal and automatic release from tail pipe.



### Hose Reels:

Manual or motorized reels for efficient hose storage and easy deployment. Ideal where overhead rails aren't suitable.



### Hose Drops & Boom Arms:

Simple, cost-effective exhaust extraction solutions with flexible reach for smaller stations or limited spaces.



### Fans:

High-performance exhaust fans provide reliable airflow to remove diesel fumes safely and efficiently.



### Control & Monitoring:

Smart controls and air monitoring systems help maintain performance and protect indoor air quality.



Fantech Industrial Ventilation offers a complete turnkey solution – from system design and recommendations, through to installation, commissioning and ongoing support. We ensure our diesel exhaust capture systems are simple to use, easy to maintain and will perform to the highest standards. We work with you at every stage of the project to create a cleaner and safer working environment for your personnel.

## 1. Design Consultation

Expert guidance to assess your station's layout size and operational needs.

## 2. Site Survey & System Recommendation

On-site evaluation with tailored recommendations to suit your specific station requirements.

## 3. Detailed Cost Breakdown

Transparent costing for streamlined installation and project planning.

## 4. Project Delivery & Implementation

Includes in-house system design and drafting, mechanical and electrical installation services, acoustic assessment, and commissioning.

## 5. After-Sales Support & Maintenance

After-sales service, maintenance, and technical support to keep your system performing effectively and efficiently.

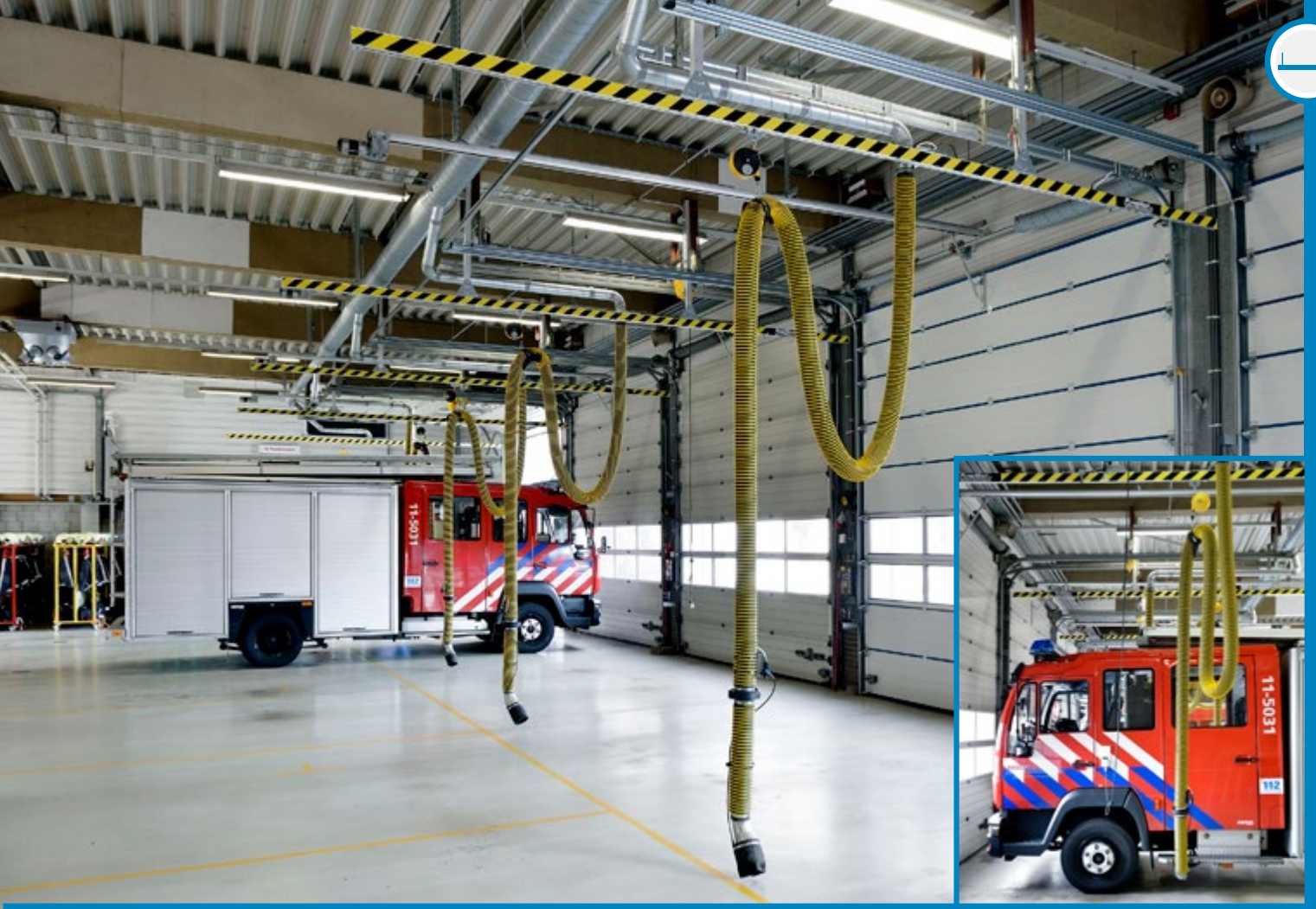

## Sliding Balancer Track (SBT)

The Sliding Balancer Track (SBT) has set the standard for exhaust extraction of fire and emergency vehicles around the world. It is designed to connect to any motor vehicle tail pipe, capturing virtually 100% of the exhaust emissions. This system is used in single, back-in applications where the vehicle tail pipe is within 12 meters of the door.

The system is fully automatic, from the fan activation to the automatic release from the exiting vehicle. There is a one-step connection to the system as the vehicle enters a station.

### Features:

- Suitable for back-in bays up to 12 meters (39.4 ft) deep
- Exhaust hose sizes for all vehicle types
- Auto-disconnect at exit door
- Speed absorbing shock system
- Fully automatic start/stop of fan by an exhaust sensor
- Adjustable release points depending on vehicle speed



### Construction

- A. Aluminium track is 5.8m in length, and custom cut to fit your application; includes Plymovent hazard stripe tape
- B. Steel trolley that travels inside the track
- C. Non-locking spring recoil balancer
- D. Upper hose
- E. Metal Saddle
- F. Mid Hose
- G. Safety Disconnect Handle and 610mm Lower Hose
- H. Pneumatic or Magnetic Grabber (Tailpipe adapter for vehicle not shown)

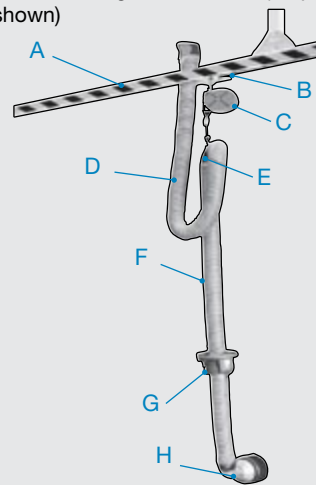

### Complete the SBT system with these necessities



Nozzles  
page 7



Handles  
page 10



Exhaust Hoses  
page 15



Fans  
page 16



MRP system with Crab Return System, Safety Disconnect Handle and Magnetic Grabber

## Mini Rail Profile (MRP)

The Mini Rail Profile (MRP) system is designed to connect to a vehicle's tailpipe to capture and remove exhaust emissions. The MRP is a fully automatic system and only requires a one-step connection as the vehicle enters the facility.

The MRP can accommodate up to two vehicles in tandem but can be also engineered to accommodate more if needed. This provides optimal extraction efficiency and an energy-efficient system. The rail is installed overhead along the service bays next to the fire apparatus and is connected to an exhaust fan.

### Features:

- Ideal for smaller apparatus bays
- Provides an economic solution for long back-in bays
- Energy efficient system
- Easy to use
- Standard design accommodates up to 2 vehicles in tandem
- TÜV SÜD safety certified product

### Crab Return System add-on option:

The Crab Return System (CRS) attaches to the MRP system to eliminate the need for an operator to physically retrieve the exhaust extraction hose and nozzle after they have been disconnected from a vehicle. The CRS automatically returns the nozzle and hose to the original starting position.



### Complete the MRP system with these necessities



Nozzles  
page 7



Handles  
page 10



Exhaust Hoses  
page 15



Fans  
page 16

## Components

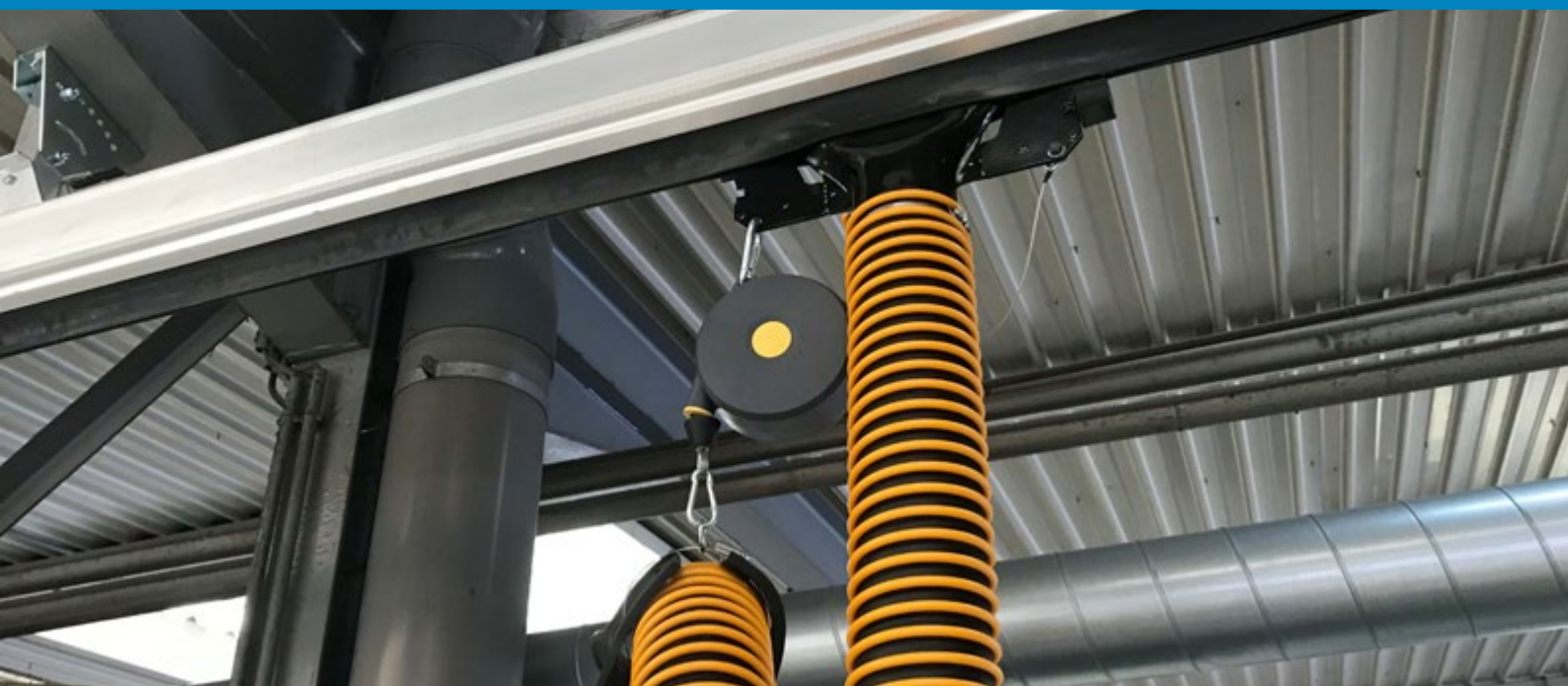
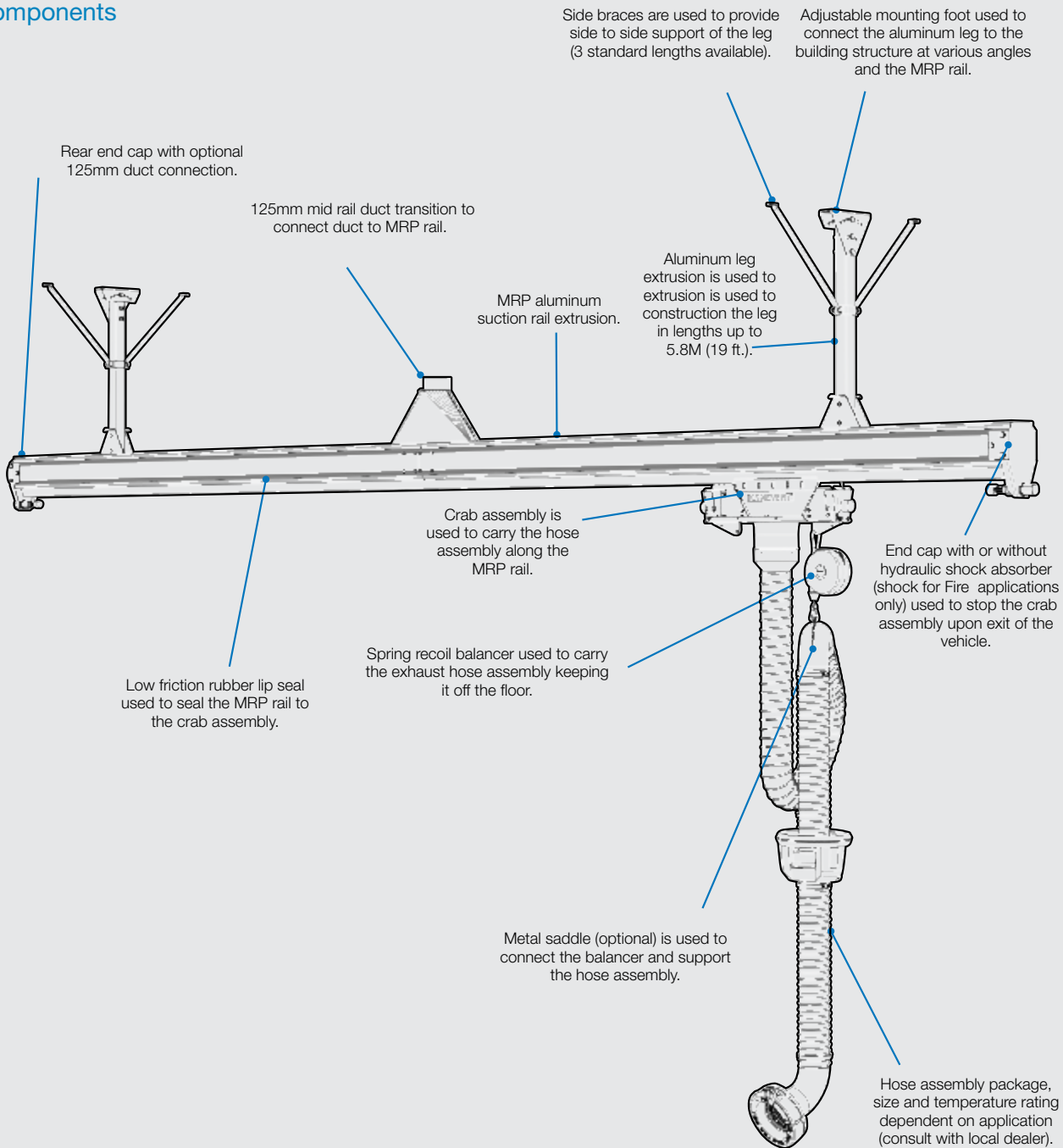



## Vertical Stack Rail (VSR)

The Vertical Stack Rail (VSR) is the solution for vehicles with overhead exhaust stacks and need to move through a station. No operator intervention is needed as the “V” shaped catcher guides the vehicle tail pipe into the rail profile.

The rail profile is a free-floating system that allows side-to-side movement and automatically aligns itself with the vehicle tail pipe. The VSR system includes a solid one-piece extruded aluminium rail profile that provides strength and durability, ensuring effective and efficient diesel exhaust gas removal.

### Features:

- Floating suspension
- Fits any vehicle stack
- Durable one-piece aluminium rail
- Expandable system to almost any length
- Adapter cone designed for empty and loaded vehicles
- 30 cm lateral movement to either side
- Flexible duct connection
- Sealing rubber lips
- Automatic return to position after lateral movement



Complete the VSR system with these necessities



Fans  
page 16



## Magnetic Grabber® (MG)

Magnetic Grabber® (MG) is a user-friendly solution for vehicle exhaust removal in fire stations. It provides a very quick, easy and controlled connection and disconnection to a vehicle exhaust system.





The strategically positioned magnets ensure a good connection to the vehicle, as well as a controlled automatic disconnect when the vehicle exits the station. To attach the Magnetic Grabber nozzle with the extraction hose to the tailpipe, the Plymovent Tailpipe Adapter needs to be connected to tailpipe of the fire truck.

### Features:

- Easy and quick to connect and disconnect
- Click and seal concept
- Self-aligning nozzle
- Rubber cover avoids damage to vehicle

### Construction



MG - COMPATIBILITY			
 RAIL SYSTEMS Page 3	 HOSE REELS Page 11	 HOSE DROPS Page 14	 EXHAUST HOSES Page 15
SBT	SER	FEB	HT
MRP	MHR	FE	ST
	MER	FEF	EH
	HRR		





Pneumatic Grabber with safety disconnect handle

## Pneumatic Grabber®

The Pneumatic Grabber connects to the vehicle exhaust pipe via an inflatable rubber bladder. The Grabber can be deflated manually or automatically and is highly suitable for Plymvent's fixed extractors and exhaust hose reels. The unique rubber construction is ideal for applications requiring a soft connection and wanting to avoid damage to the vehicle's exhaust tail pipe.

### Features:

- Nozzles are easy and quick to connect and disconnect
- Manual or automatic deflation to disconnect the nozzle from the vehicle
- Ideal for tailpipes that require a soft connection

### Construction



### PNEUMATIC GRABBER - COMPATIBILITY

RAIL SYSTEMS Page 3	HOSE REELS Page 11	HOSE DROPS Page 14	EXHAUST HOSES Page 15	HANDLES Page 10
SBT	SER	FEB	HT	Safety Disconnect Handle
MRP	MHR	FE	ST	
	MER	FEF	EH	
	HRR			



## Rubber Nozzle with Vice Grip (REG)

The REG nozzle is equipped with a vice grip to maximise its holding power to the tailpipe. The REG is designed to take in ambient cooling air thereby reducing the exhaust emission temperature. The nozzle is composed of moulded, high temperature resistant rubber. It also includes a CO-outlet for measuring emission values.

### Features:

- Easy and quick to connect and disconnect
- Maximum holding power to the tailpipe
- The oval adapter can work on dual exhaust pipes



## BAYONET QUICK LOCK

The Bayonet Quick Lock enables fire and emergency vehicles with the Plymovent Magnetic Grabber® Tailpipe Adapter to be hooked up to the Plymovent Pneumatic Grabber® or similar nozzles. The Bayonet Quick Lock easily connects to the tailpipe adapter so that the Pneumatic Grabber nozzle can be attached to the vehicle.

### Features

- High-grade stainless steel, electro polished
- Installs quickly by hand; no tools necessary
- Makes exhaust removal systems compatible across fire and emergency communities
- The brim plate contains two spring-loaded plunger metal pins and twist lock
- Fits into the 125mm Plymovent Magnetic Grabber Tailpipe Adapter

## Metal Exhaust Nozzle (MEN)

Recommended for engine testing and natural gas engine service facilities, the Metal Exhaust Nozzle (MEN) can handle temperatures up to 300°C (550°F) continuous or up to 650°C (1200°F) intermittent. The nozzle is made up of a powder coated metal pipe and a spring-loaded rubber lid. The lid shuts tight and functions as a damper when the nozzle is not being used

### Features:

- Easy and quick to connect and disconnect
- Suitable for fixed extractors and hose reels





Safety Disconnect Handle within an MRP system with Crab Return System and Magnetic Grabber



## Safety Disconnect Handle

The Safety Disconnect Handle is designed for the safe and easy operation of your vehicle exhaust removal system. It prevents the user from having to bend down to connect the exhaust removal system thus limiting the danger of exposure to exhaust gases.

With an uninterrupted flow through the exhaust removal hose, the exhaust gases are transported efficiently out of the breathing zone.

### Features:

- Scratch-safe, high temperature resistant materials
- Maximum efficiency through uninterrupted airflow through the hose
- Ergonomic in use and operation
- Available for both magnetic and pneumatic systems
- Can be used on all existing systems



## Construction

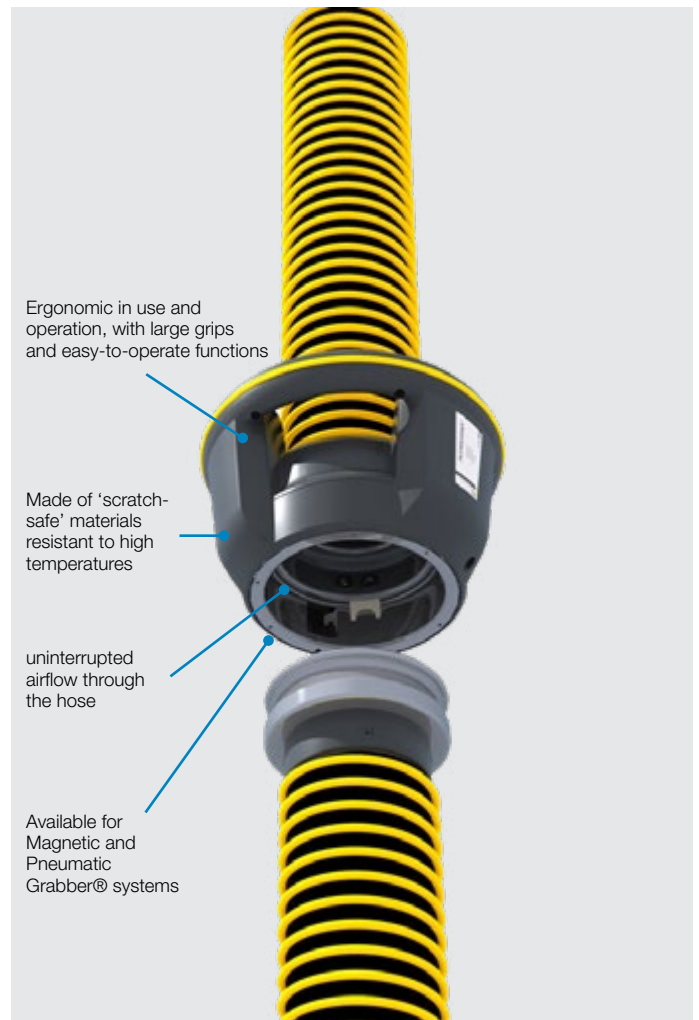

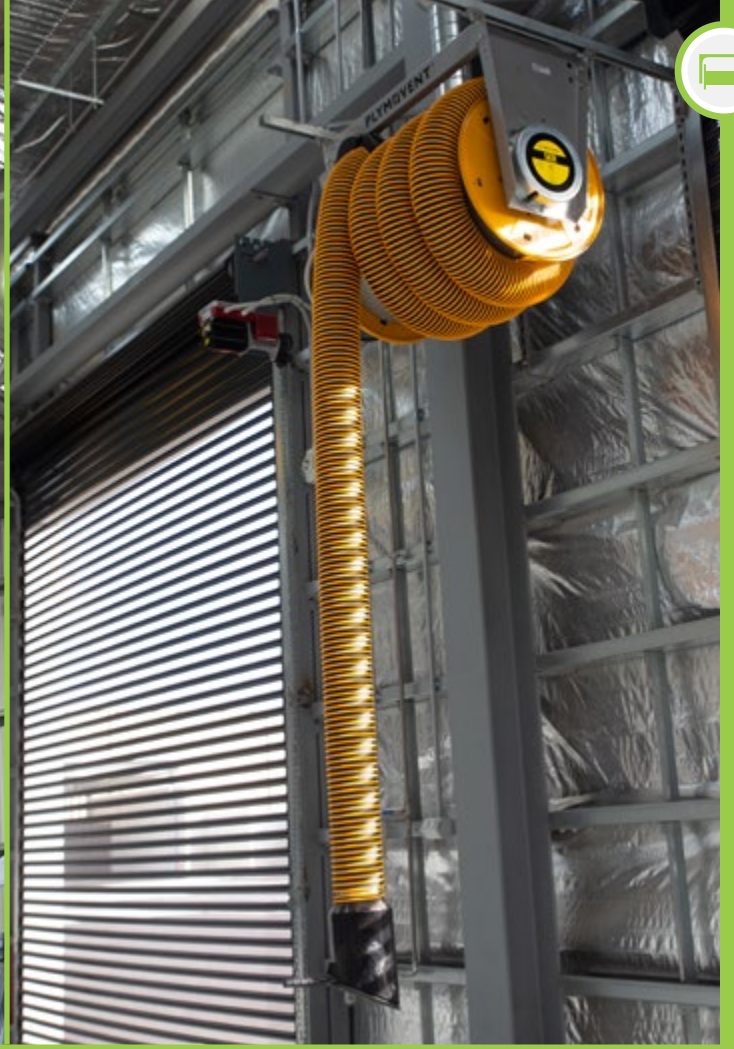

## Spring-Operated Extraction Hose Reel (SER)

The Spring-Operated Extraction Hose Reel (SER) is designed to retract hoses up to 12.5m in length with the assistance of a spring. The sealed drum provides smooth operation and protects the hose from everyday wear and tear. The SER hose reel can lock in the desired position or rewind to the end through a simple pull mechanism.

### Features:

- Operates smoothly thanks to the spring balanced operation
- Can be installed on a wall or the ceiling
- Suitable for hoses up to 12.5m in length
- Robust maintenance free design



### SER - COMPATIBILITY

NOZZLES page 7	HANDLES Page 10	EXHAUST HOSES Page 15	FANS Page 16
Magnetic Grabber	Safety Disconnect Handle	HT	FUA
Pneumatic Grabber		ST	TEV
MEN		EH	SAF

### DID YOU KNOW?

Nitrogen oxides found in diesel exhaust can damage lung tissue, lower the body's resistance to respiratory infection and worsen chronic lung diseases, such as asthma.



MHR – Motorised Hose Reel



MER – Motorised Exhaust Reel

## Motorised Hose Reels (MHR & MER)

The MHR and MER Motorised Hose Reels are both engineered for efficient hose storage and effortless retraction using powerful electric motors. These reels provide safe, reliable, and easy operation and are available in a range of sizes and control options:

### MHR – Motorised Hose Reel

Ideal for applications with limited ceiling height, the MHR is a practical and easy-to-operate solution.

#### Key features:

- Robust design
- Available in 850mm and 1050mm drum widths
- Optional automatic valve
- Sealed motor compartment for protection and service access
- Various control systems available



### MER – Motorised Exhaust Reel

Built to handle larger and heavier hoses, the MER is ideal for intensive exhaust extraction applications.

#### Key features:

- High-torque gear motor drive system for maximum lifting capacity
- Trouble-free operation
- Ideal for storing large and heavy exhaust hoses
- End position limit switch for safe handling
- Suitable for hose lengths up to 12.5m
- Various control systems available



### MHR & MER - COMPATIBILITY

NOZZLES page 7	HANDLES Page 10	EXHAUST HOSES Page 15	FANS Page 16
Magnetic Grabber	Safety Disconnect Handle	HT	FUA
Pneumatic Grabber		ST	TEV
MEN		EH	SAF
REG			



## Hose Reel on Rail (HRR)

The Hose Reel on Rail (HRR) allows the extraction hose to be shared between multiple bays.

The HRR system effortlessly slides along the rail to the desired location. The hose can then be easily lowered and connected to the vehicle using the nozzle. When not in use the exhaust hose reel can be easily positioned in a non-working zone.

### Features:

- Ideal for use in facilities with multiple bays
- Operators can slide the hose reel easily along the rail to the desired position
- Systems available for large and small fire stations
- One Hose Reel on Rail System is able to work with multiple bays



### HRR - COMPATIBILITY

NOZZLES page 7	HANDLES Page 10	EXHAUST HOSES Page 15	FANS Page 16
Magnetic Grabber	Safety Disconnect Handle	HT	FUA
Pneumatic Grabber		ST	TEV
MEN		EH	SAF
REG			



### Fixed Exhaust Dropper on Boom Arm (FEB)

The Fixed Exhaust Dropper on Boom Arm (FEB) is designed to cover a wide area with a simple hose drop system. The swing arm has an 8 metre reach and can fold back, thus minimising the area that the FEB needs when installed. The FEB can be attached to a central fan system or connected to a direct-mounted fan depending on the facility situation.

#### Features:

- Ideal for fire stations with no fixed vehicle positions
- 8 metre reach
- Designed to cover a wide area





### Fixed Extractor Hose Drop (FE) & (FEF)

The Fixed Extractor (FE) single hose drop is a simple and economic solution when you have to extract exhaust gases and cover more than one service bay while using a central extraction system. With the extraction hose connected directly to the ductwork or a fan (in the case of the FEF) you have an easy but efficient system in use.

#### Features:

- Suits small fire stations with limited space
- Provides efficient exhaust extraction
- Can cover more than one service bay

### FEB, FE & FEF - COMPATIBILITY

 NOZZLES page 7	 EXHAUST HOSES Page 15	 FANS Page 16
Magnetic Grabber	HT	FUA
Pneumatic Grabber	ST	TEV
MEN	EH	SAF
REG		





### Highly Crush Resistant Hose (EH)

The EH is a vibration resistant and crush-proof hardened hose recommended for areas where vehicles might drive over the hose. It is designed for exhaust gas temperatures up to 200°C (392°F).

#### Features:

- Resistant to all chemicals present in exhaust fumes
- Highly flexible and compressible
- Protected, flow-optimising exterior folds



### Standard Temperature Hose (ST)

The Standard Temperature Hose (ST) is an abrasion-resistant and highly flexible hose. The hose wall is made of a high-quality synthetic fabric that can withstand temperatures up to 204°C (400°F) continuous in a properly designed system. Intermittently, the ST hose can endure 316°C (600°F) provided there is a sufficient supply of fresh air.

#### Features

- External helix is made up of spring steel wire and a synthetic wear strip for abrasion resistance
- Lower hose is constructed with a proprietary semi-rigid material to ensure proper operation with Plymovent Grabbers



### High Temperature Hose (HT)

The High Temperature Hose (HT) is a high-quality, flame and abrasion resistant hose. It can withstand temperatures up to 482°C (900°F) continuous in a properly designed system. Intermittently, the HT hose can endure 566°C (1050°F) provided there is a sufficient supply of fresh air.

#### Features

- Hose wall is made of a proprietary multi-layer, high temperature synthetic fabric hose
- External helix is made up of spring steel wire and a synthetic wear strip for abrasion resistance
- Lower hose is constructed with a proprietary semi-rigid material to ensure proper operation with Plymovent Grabbers



## FUA Fan Series

The FUA fans can be used in direct mount exhaust extraction systems such as rails and hose reels. Can also be used as a central fan in small extraction systems. These fans are equipped with lightweight aluminium impellers, suitable for extracting exhaust gases, volatile fumes and dust.

IP55 rated; sufficient protection against dust, and can withstand high pressure water cleaning.

### Features:

- Direct mount
- Rotational outlet
- Casing made from durable powder coated galvanised steel
- Mounting bracket available
- Available in 4 models from 55kW to 2.2kW



### FACT

The World Health Organisation (WHO) classified diesel engine exhaust as carcinogenic to humans (Group 1), based on sufficient evidence that exposure is associated with an increased risk for lung cancer.



## Fan in sound-absorbing box (SAF)

The SAF range combines a Plymovent TEV fan and a robust sound absorbing case. The SAF is recommended for spaces where noise pollution needs to be controlled. They minimise noise output and are suitable for both indoor or outdoor installations. Combined with the recommended duct silencer, SAF fans are more than 10 dB quieter than a standard TEV fan. The SAF features a neat sleek finish and a load bearing top plate.

### Features:

- Can reduce noise output by more than 10 dB when combined with the recommended duct silencer
- Available in 4 sizes ranging from 0.75 to 7.5 kW
- Suitable for both indoor and outdoor use
- Neatly finished for a professional and sleek appearance

### Noise Level SAF

(with additional duct silencer)

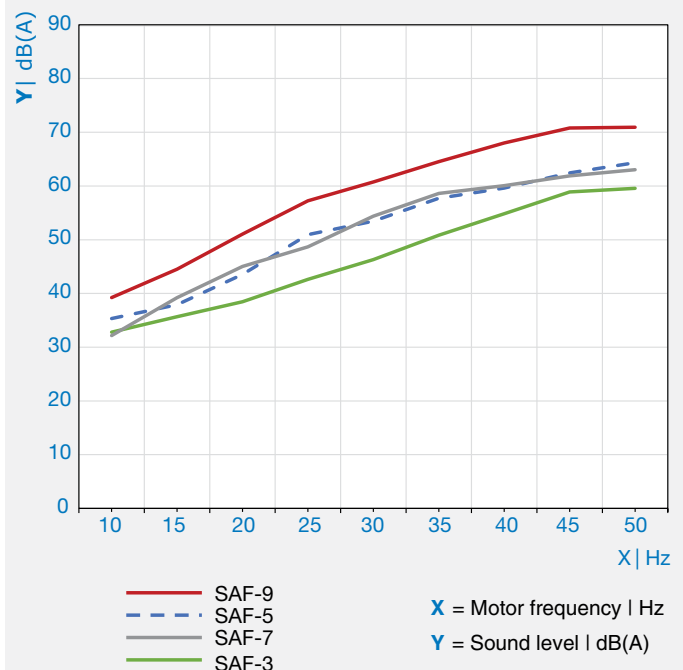

Test data based on SAF fans with additional duct silencer. Plymovent highly recommends the use of a duct silencer.



## TEV Fan Series

The TEV series ventilation fans are designed for large central fan systems with multiple extraction points. These fans are equipped with lightweight aluminium impellers, suited for exhausting gases, volatile fumes and dust. These high capacity fans ensure even air flow and low noise levels.

### Features:

- Available in 4 models from .75 to 7.5 kW
- Energy efficient
- Easy to mount housing
- Controllable by frequency inverter
- IP55 rated, can withstand high pressure water cleaning



## AeroGuard

AeroGuard gives you real-time transparency and assurance of the quality of your indoor air. It has a wide range of sensors, monitoring eleven pollutants and climate factors. The LED ring enables you to focus on the contaminant most important to you.

### Features:

- Real-time monitoring with historical data display
- Seven calibration settings including custom calibration of dust sensor
- Mobile app included for real-time information
- Powerful dedicated web portal with intelligent features
- Customisable factory mapping with air monitor alerts



Scan code to view full specifications



Scan code to watch how the AeroGuard works



# THE DANGERS OF DIESEL EXHAUST

## AND WHY YOU NEED TO HOOK UP THE HOSE



### NIOSH states there can be no safe level of exposure to a carcinogen

Therefore a reduction of worker exposure to chemical carcinogens as much as possible through elimination or substitution and engineering controls is the primary way to prevent occupational cancer.



### The World Health Organisation classified diesel engine exhaust as carcinogenic to humans

Based on sufficient evidence that exposure is associated with an increased risk for lung cancer.

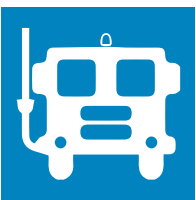

### Local exhaust extraction is needed, even with modern diesel engine technology

A NIOSH study completed in 2016 (HHE Report No. 2015-0159-3265), recommends a local exhaust ventilation system for a station, despite the station carrying modern engines that employed ultra-low sulfur diesel fuel and contained diesel particulate filter and regeneration systems.



### Diesel exhaust is being linked to life threatening illnesses

Men with a higher exposure to diesel exhaust over a 5 to 10 year period were at least 20% more likely to develop ALS than men with no exposure. Source: Aisha Dickerson, PhD, Harvard T.H. Chan School of Public Health

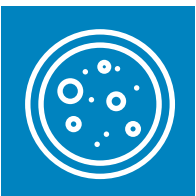

### Undefined Exposure Limits

Diesel exhaust contains gases, particulate and more than 40 potentially toxic compounds. And yet, occupational exposure limits for diesel particulate matter have not been established by OSHA or NIOSH. Source: ncbi.nlm.nih.gov



### Ultrafine particles may result in more adverse effects than fine particles

Ultrafine particles can penetrate into the small airways and alveolar region, where they may exist for weeks or months. Source: Oberdörster G. Pulmonary effects of inhaled ultrafine particles. Int. Arch. Occup. Environ. Health. 2000;74(1):1-8.

## REMOVE THE DANGERS OF DIESEL EXHAUST

Hazardous vehicle exhaust emissions in your facility can be the most significant cancer health risk and also a serious legal liability. Eliminate this hazard with Plymovent code compliant\* vehicle exhaust capture and removal systems. From existing to new turn-key facilities, our totally automatic start-up and disconnect source capture systems are the recommended method for controlling exhaust emissions in your fire station.

## SOLUTIONS FOR EXPOSURE TO EXHAUST FUMES

Plymovent aims to deliver quality systems that are safe, user friendly, regulation compliant and will enhance the quality of life for your firefighters and emergency service personnel. That is why Plymovent have developed a line of source capture systems designed to meet your station's needs:

- Under Carriage Rail Systems - for drive through bays with up to four vehicles
- Vertical Stack Rail Systems - for vehicles with overhead exhaust stacks
- Under Carriage Track Systems - for single and double bay applications

\*Code compliant if properly designed, installed and/or maintained in specific facility application.

Scan code to watch the Plymovent Diesel Exhaust Source Capture systems in operation

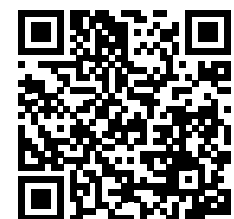

# Compatibility Chart

## Plymovent Diesel Exhaust Source Capture Systems Overview



### RAIL SYSTEMS

MRP	VSR	SBT
<b>COMPATIBLE EXHAUST HOSES</b>		
HT ST EH	N/A	HT ST EH
<b>COMPATIBLE NOZZLES/HANDLES</b>		
Magnetic Grabber Pneumatic Grabber Safety Disconnect Handle	N/A	Magnetic Grabber Pneumatic Grabber Safety Disconnect Handle
<b>COMPATIBLE FANS</b>		
FUA TEV SAF	FUA TEV SAF	FUA TEV SAF



### HOSE REELS

SER	MHR	MER	HRR
<b>COMPATIBLE EXHAUST HOSES</b>			
HT ST EH	HT ST EH	HT ST EH	HT ST EH
<b>COMPATIBLE NOZZLES/HANDLES</b>			
Magnetic Grabber Pneumatic Grabber Metal Exhaust Nozzle Safety Disconnect Handle	Magnetic Grabber Pneumatic Grabber Metal Exhaust Nozzle Safety Disconnect Handle Rubber Nozzle with Vice Grip	Magnetic Grabber Pneumatic Grabber Metal Exhaust Nozzle Safety Disconnect Handle Rubber Nozzle with Vice Grip	Magnetic Grabber Pneumatic Grabber Metal Exhaust Nozzle Safety Disconnect Handle Rubber Nozzle with Vice Grip
<b>COMPATIBLE FANS</b>			
FUA TEV SAF	FUA TEV SAF	FUA TEV SAF	FUA TEV SAF



### HOSE DROPS

FEB	FE & FEF
<b>COMPATIBLE EXHAUST HOSES</b>	
HT ST EH	HT ST EH
<b>COMPATIBLE NOZZLES/HANDLES</b>	
Magnetic Grabber Pneumatic Grabber Metal Exhaust Nozzle Rubber Nozzle with Vice Grip	Magnetic Grabber Pneumatic Grabber Metal Exhaust Nozzle Rubber Nozzle with Vice Grip
<b>COMPATIBLE FANS</b>	
FUA TEV SAF	FUA TEV SAF

**THERE ARE NO SAFE LEVELS OF EXPOSURE TO DIESEL EXHAUST**

Take the next step towards a cleaner and safer fire station today. For sales enquiries please contact:

**Leigh Howard - Head of Special Projects**

**Mob: 0403 298 681**

**Email: lhoward@fantech.com.au**



**FANTECH**  
Industrial Ventilation