

# Delivering More Control and Efficiencies



The fully adjustable, **TD EVO VAR** inline fan provides an innovative and highly efficient solution for domestic and commercial ventilation needs. The range offers integrated variable speed control, analogue input signal and run-on-timer.



**FANTECH**  
Intelligent Ventilation

# An Energy Efficient Solution

Continual increases in energy costs have created greater demands for products and systems that minimise energy usage.

The TD EVO VAR in-line fan has been designed to provide highly efficient, mixed-flow performance with low energy consumption for domestic and commercial applications. It takes advantage of an integrated variable speed controller that can be adjusted locally on the fan, or remotely via a 0-10V or 4-20mA analogue input signal. The TD EVO VAR also comes standard with an on-board, adjustable 1 to 30 minute run-on-timer that allows steam and odour to be exhausted after leaving the room.

## Optimised Impeller Design

The low-profile compact design of the TD EVO VAR makes it well suited for ventilation applications where space is limited such as hotels and apartments.

Its optimised impeller design, guide vane and outlet diffuser helps increase air flow performance. The silent block between the motor and the guide vane helps reduce motor vibration and lowers the overall sound level.



# Key Features

- 6 fan sizes: Suits 100, 125, 150, 200, 250 and 315mm duct diameters
- Speed controllable via on-board potentiometer or external 0-10V or 4-20mA signal
- Optimised impeller, guide vanes, and outlet diffuser for low noise operation
- Main fan body is easily removed without dismantling ducting
- Highly efficient single-phase AC motor
- Rated Class F Insulation, IP44
- Fan can be mounted in any position
- Junction box can be rotated to any position
- Integrated run-on-timer (0, 1, 5, 15 and 30 minutes)



# Purpose Built for Easy Installation

Installation and maintenance of the TD EVO VAR is made simple with an easy to remove fan body. This allows for the support bracket to be easily screwed into place and the ductwork attached. It has an airtight construction with double injection sealing between the main body and the support bracket to avoid air leaks. Rubber gaskets are also on the flanges for improved airtightness with the attached ducts.



# On-board Configuration

To save on time and installation cost, the TD EVO VAR comes with on-board speed control, input signal selection and an adjustable run-on-timer as standard.

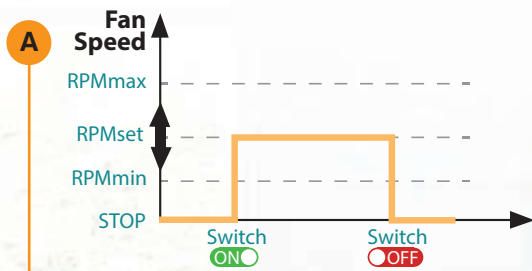

Operating with external on/off switch at a predetermined speed between RPMmin & RPMmax, set by internal potentiometer.

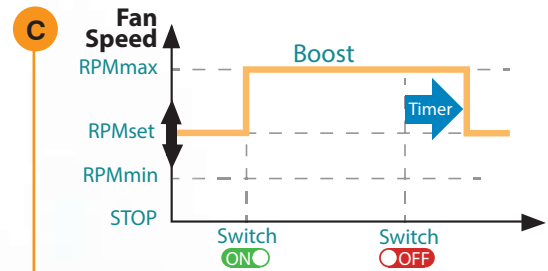

As per B, with an adjustable 1-30min run on time once the external switch has been turned off.

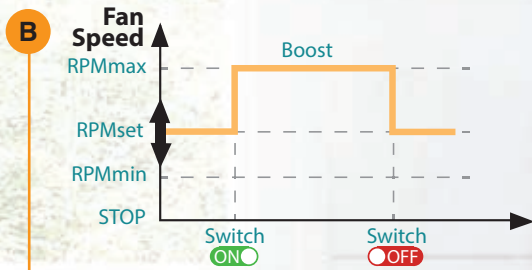

Operating continuously at a predetermined speed between RPMmin & RPMmax, set by internal potentiometer, and going to RPMmax when external switch is turned on.

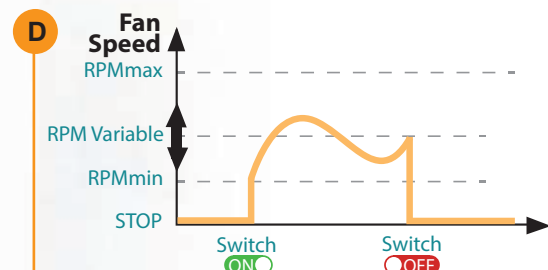

Operating with external on/off switch, the speed can be manually adjusted via an external Potentiometer or 0-10V or 4-20mA signal.

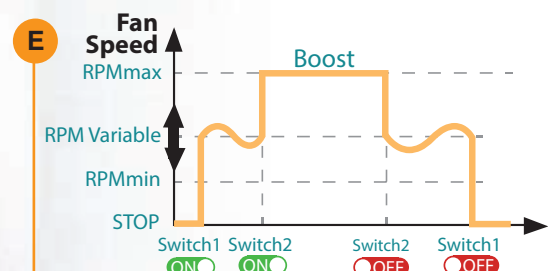

As per D, with an external switch for operation at RPMmax.

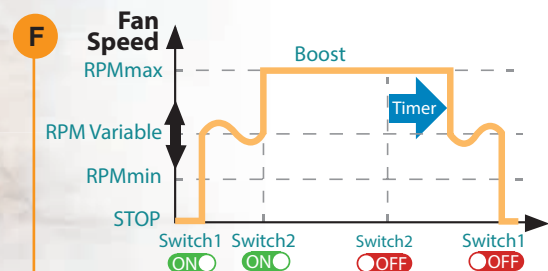

As per E, with an adjustable 1-30min run on time once the external switch has been turned off.



Easy to install



Energy saver



Quiet operation



Optimised impeller design

## Performance Curve

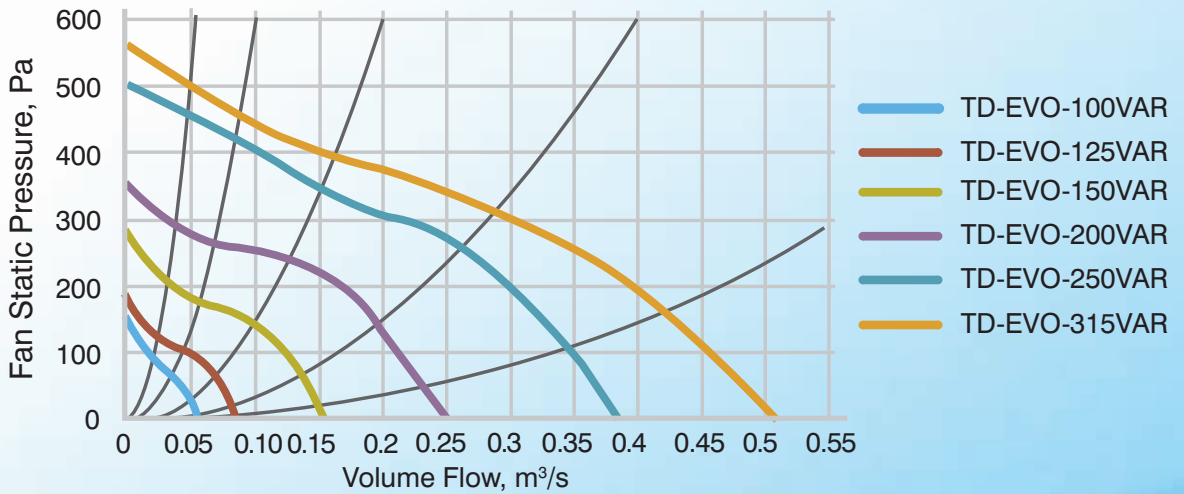

## Dimensions

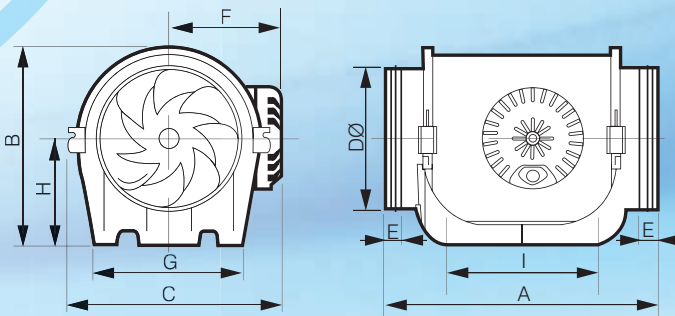

Model Number										App. Wt. kg
TD-EVO-...	A	B	C	DØ	E	F	G	H	I	
100VAR	302	181	201	97	28	107	133	100	168	1.7
125VAR	302	191	221	122	28	117	132	100	172	1.8
150VAR	326	221	240	147	25	126	165	120	170	3.0
200VAR	346	238	263	197	28	137	190	124	211	4.1
250VAR	390	289	306	247	40	159	230	155	231	6.2
315VAR	485	353	371	312	40	192	278	188	317	8.4

Dimensions in mm



## Technical Data

Model Number	Fan Speed rev/sec	Avg. dB(A) @ 3m*	TD-EVO-...1ph Watts	TD-EVO-...1ph Amps	Max. amb °C
100VAR	41	31	16	0.1	60
125VAR	39	36	29	0.1	60
150VAR	44	44	45	0.2	60
200VAR	45	47	107	0.5	60
250VAR	45	52	181	0.8	60
315VAR	44	56	273	1.1	60

\* Inlet Sound Levels



**FANTECH**

Intelligent Ventilation

### Fantech Pty. Ltd.

Victoria: (+61 3) 9554 7845  
 New South Wales: (02) 8811 0400  
 South Australia: (08) 8294 0530  
 Northern Territory: (08) 8947 0447  
 Queensland: (07) 3299 9888  
 Western Australia: (08) 9209 4999  
 A.C.T.: (02) 6280 5511  
 Tasmania: (03) 6273 6455  
 New Zealand: (09) 444 6266

[www.fantech.com.au](http://www.fantech.com.au) |

For sales enquiries contact:

Specifications and design subject to change without notice.